

2021 IECC ELECTRICAL CONDITIONS

2021 IECC GENERAL CONDITIONS:

THE FOLLOWING SPECIFICATIONS AND REQUIREMENTS ARE ALL PER IECC 2021:

LIGHTING CONTROLS

- OCCUPANT SENSOR CONTROLS SHALL BE INSTALLED TO CONTROL LIGHTS IN ALL SPACE TYPES INCORPORATED WITH IECC 2021 - C405.2.1.
- CONTRACTOR TO PROVIDE REQUIRED OCCUPANT SENSORS AND CONTROLS TO COMPLY WITH IECC 2021 - C405.2.1.3 (OPEN OFFICE SPACES).
 - CONTROL ZONES ARE NOT TO EXCEED 800 SQUARE FEET.
 - AUTO ON PROMPTED IN OCCUPIED ZONES, AUTO ON PROMPTED IN UNOCCUPIED ZONES WITHIN SPACE TO NO MORE THAN 20% FULL POWER.
 - GENERAL LIGHTING TO TURN OFF NO LATER THAN 20 MINUTES AFTER ALL OCCUPANTS HAVE LEFT CONTROL ZONE.
 - GENERAL LIGHTING IN EACH ZONE TO AUTO OFF OR UNIFORMLY REDUCE LIGHTING POWER TO NO MORE THAN 20% OF FULL POWER WITHIN 20 MINUTES OF ALL OCCUPANTS LEAVING.
- PER IECC 2021 - C405.2.2 - CONTRACTOR TO PROVIDE OCCUPANCY SENSORS IN CORRIDORS TO UNIFORMLY REDUCE LIGHTING POWER TO NO MORE THAN 50% OF FULL POWER 20 MINUTES AFTER OCCUPANTS HAVE LEFT THE SPACE.
 - WHERE OPEN OFFICES ARE GREATER THAN 300 SQUARE FEET, COMPLY WITH IECC 2021 - C405.2.1.1.
 - ALL LIGHTING MAY AUTO OFF WITH TIME SWITCH.
- PER IECC 2021 - C405.2.2 - CONTRACTOR TO PROVIDE TIME-SWITCH CONTROL IN EACH SPACE NOT PROVIDED WITH OCCUPANCY SENSOR CONTROLS COMPLYING WITH SECTION C405.2.1. TIME-SWITCH CONTROLS SHALL COMPLY WITH SECTION C405.2.1.
 - AUTO OFF WHEN SPACE IS SCHEDULED TO BE UNOCCUPIED.
 - INCLUDE MANUAL OVERRIDE TO PERMIT UP TO 2 HOURS OF USE IN CONTROL AREA NOT LARGER THAN 5,000 SQUARE FEET.
- CONTRACTOR TO PROVIDE READILY ACCESSIBLE MANUAL CONTROL IN SPACES REQUIRING REDUCED LIGHTING CONTROL, IN COMPLIANCE WITH IECC 2021 - C405.2.2. CONTROLLED LIGHTING TO BE VISIBLE FROM CONTROL DEVICE CONTROL DEVICE TO HAVE SWITCHING OR DIMMING IN COMPLIANCE WITH IECC 2021 - C405.2.2.1.
 - SPACES WHERE THE GENERAL LIGHTING LOAD EXCEEDS 150W WITHIN PRIMARY SCHEDULED DAYLIGHT ZONES OR EXCEEDS 300W IN SECONDARY SCHEDULED DAYLIGHT ZONES IN ACCORDANCE WITH C405.2.4.2.
 - SPACES WHERE THE GENERAL LIGHTING LOAD EXCEEDS 150W WITHIN TOPPLIT DAYLIGHT ZONES IN ACCORDANCE WITH SECTION C405.2.4.3.
- PER IECC 2021 - C405.2.7 - CONTRACTOR TO PROVIDE AUTOMATIC CONTROLS FOR EXTERIOR LIGHTS, EXTERIOR LIGHTS SHALL AUTO OFF WHEN DAYLIGHT SATISFIES LIGHTING NEEDS, FACADE AND LANDSCAPE LIGHTS TO AUTO OFF BY ONE HOUR AFTER BUSINESS CLOSE, UNTIL ONE HOUR BEFORE BUSINESS OPEN, ALL OTHER LIGHTING TO REDUCE POWER BY NO LESS THAN 50% AND NO LATER THAN MIDNIGHT TO 8 AM, ONE HOUR AFTER CLOSING TO ONE HOUR BEFORE OPENING, OR 15 MINUTES OF NO DETECTED ACTIVITY.
- LUMINAIRES IN OUTDOOR PARKING SPACES SHALL BE FITTED WITH CONTROLS TO REDUCE POWER TO NO MORE THAN 50% WHEN NO ACTIVITY IS DETECTED FOR MORE THAN 15 MINUTES. CONTROL ZONE SHALL BE NO MORE THAN 1500W.
- NO CONTROLS REQUIRED FOR LIGHTING FOR COVERED VEHICLE ENTRANCES AND EXITS FROM BUILDINGS AND PARKING STRUCTURES WHERE REQUIRED FOR EYE ADAPTATION.
- PER IECC 2021 - C405.2.8 - PARKING GARAGE LIGHTING TO BE CONTROLLED BY OCCUPANCY SENSOR COMPLYING WITH SECTION C405.2.1.1 OR TIME-SWITCH CONTROL, COMPLYING WITH SECTION C405.2.2.1. CONTRACTOR TO PROVIDE ADDITIONAL LIGHTING CONTROLS IN ACCORDANCE WITH SECTION C405.2.8(1) - C405.2.8(3).
 - EACH LUMINAIRE'S LIGHTING POWER SHALL BE AUTO REDUCED BY NO LESS THAN 30% WHEN NO ACTIVITY IS DETECTED FOR 20 MINUTES. CONTROL ZONE TO BE NO MORE THAN 3,000 SQUARE FEET.
 - LIGHTING FOR EYE ADAPTATION TO BE INDEPENDENTLY CONTROLLED TO AUTO REDUCE POWER BY NO MORE THAN 40% FROM SUNSET TO SUNRISE.
 - LUMINAIRE POWER WITHIN 20 FEET OF PERIMETER WALL OPENINGS TO AUTO REDUCE BY NO MORE THAN 50% IN RESPONSE TO DAYLIGHT.

RECEPTACLE CONTROLS

- PER IECC 2021 - C405.11 - CONTRACTOR TO PROVIDE ONE OF THE FOLLOWING AUTOMATIC RECEPTACLE CONTROLS FOR NO LESS THAN 20% OF 120V, 15A & 20A RECEPTACLES IN CLOSED OFFICES, CONFERENCE ROOMS, COPY/PRINT ROOMS, BREAK ROOMS, CLASSROOMS, AND INDIVIDUAL WORKSTATIONS. HALF OF CIRCUITS FOR INDIVIDUAL WORKSTATIONS TO BE CONTROLLED. FURNITURE VENDOR SHALL USE THE CONTROLLED CIRCUITS TO COMPLY WITH REQUIREMENTS (HALF OF RECEPTACLES CONTROLLED, AND UNCONTROLLED WITHIN 72 INCHES FROM CONTROLLED). TIME-CONTROLS WITH PROGRAMMABLE TIMES FOR EACH DAY OF THE WEEK. INDEPENDENT SCHEDULE TO BE PROVIDED FOR SPACES NO MORE THAN 5000 SQUARE FEET AND NO MORE THAN 1 FLOOR. OCCUPANT ACCESSIBLE MANUAL OVERRIDE TO BE PROVIDED, OPERATING FOR NO MORE THAN 2 HOURS AT A TIME WITH A CONTROL ZONE OF NO MORE THAN 500 SQUARE FEET.
 - OCCUPANT SENSOR TO TURN OFF RECEPTACLES WITHIN 20 MINUTES OF ALL OCCUPANTS LEAVING THE CONTROL SPACE.
 - AN AUTOMATIC SIGNAL FROM ANOTHER CONTROL DEVICE SET TO AUTO OFF RECEPTACLES WITHIN 20 MINUTES OF THE SPACE BEING UNOCCUPIED.
 - RECEPTACLES DESIGNATED FOR 24-HOUR EQUIPMENT.
 - SPACES WHERE AUTOMATIC CONTROL WOULD ENDANGER THE SAFETY OR SECURITY OF THE ROOM OR OCCUPANTS.
 - EITHER TOP DUPLEX RECEPTACLE MUST BE CONTROLLED, OR CONTROL RECEPTACLE MUST BE INSTALLED WITHIN 12 INCHES OF UNCONTROLLED RECEPTACLE, IN COMPLIANCE WITH C405.11(1).

EXCEPTION: WITHIN A SINGLE MODULAR OFFICE WORKSTATION, UNCONTROLLED RECEPTACLE PERMITTED BEYOND 12 INCHES, BUT NO MORE THAN 72 INCHES FROM CONTROLLED RECEPTACLE.
 - CONTROLLED RECEPTACLES TO BE PERMANENTLY MARKED IN ACCORDANCE WITH NFPA 70, IN COMPLIANCE WITH C405.11(3).
 - PER C405.11(4), PLUG-IN DEVICES AND CONTROLLED POWER STRIPS SHALL NOT COMPLY.
- OTHER
- PER IECC 2021 - C405.5.3 - GAS-FIRED LIGHTING APPLIANCES SHALL NOT BE EQUIPPED WITH CONTINUOUSLY BURNING PILOT LIGHTING SYSTEMS.
 - PER IECC 2021 - C405.7 - LOW-VOLTAGE DRY-TYPE DISTRIBUTION ELECTRIC TRANSFORMERS, IN ACCORDANCE WITH C405.7, MUST COMPLY WITH THE EFFICIENCY REQUIREMENTS IN TABLE C405.7.
 - PER IECC 2021 - C405.8 - ELECTRIC MOTOR, IN ACCORDANCE WITH C405.8, MUST COMPLY WITH THE MINIMUM EFFICIENCY REQUIREMENTS OF THE TABLES C405.8(1) THROUGH C405.8(4).
 - PER IECC 2021 - C405.9.1 - LUMINAIRES IN EACH ELEVATOR CAB, EXCLUDING SIGNALS AND DISPLAYS, MUST OPERATE AT NO LESS THAN 25 LUMENS/WATT. VENTILATION FANS, WITHOUT INDEPENDENT AIR-CONDITIONING SYSTEMS, MUST NOT CONSUME MORE THAN 0.33 WATTS/CFM. CONTRACTOR TO PROVIDE CONTROLS TO DE-ENERGIZE LIGHTING AND VENTILATION FANS WHEN ELEVATOR IS STOPPED, UNOCCUPIED, AND WITH ITS DOOR CLOSED FOR NO LESS THAN 15 MINUTES.
 - PER IECC 2021 - C405.12 - CONTRACTOR TO PROVIDE ENERGY MONITORING SYSTEMS TO COMPLY WITH C405.12.1 THROUGH C405.12.5 WHEN THE GROSS CONDITIONAL FLOOR AREA IS NOT LESS THAN 25,000 SQUARE FEET.
 - PER IECC 2021 - C408.3 - CONTRACTOR TO PROVIDE FUNCTIONAL TESTING OF LIGHTING CONTROLS TO COMPLY WITH C408.3.1 THROUGH C408.3.2.

2021 IECC EXISTING BUILDING NOTES:

THE FOLLOWING IECC REQUIREMENTS ARE INTENDED TO ACT AS SUPPLEMENTAL INFORMATION FOR EXISTING BUILDINGS AND SPACES. THE ABOVE 2021 IECC REQUIREMENTS SHALL STILL BE MET.

ADDITIONS

- PER IECC 2021 - C502.3.6 - NEW LIGHTING SYSTEMS, INSTALLED AS PART OF THE ADDITION, SHALL COMPLY WITH SECTIONS C405 & C408.

ALTERATIONS

- PER IECC 2021 - C503.5 - NEW LIGHTING SYSTEMS, INSTALLED AS PART OF THE ADDITION, SHALL COMPLY WITH SECTIONS C405 & C408.

EXCEPTION:

 - ALTERATIONS THAT REPLACE LESS THAN 10% OF THE LUMINAIRES IN THE SPACE, PROVIDED NO INCREASE IN THE INSTALLED INTERIOR LIGHTING POWER. (THIS EXEMPTION DOES NOT APPLY TO POWER AND CONTROLLED RECEPTACLES)

CONTROL WIRING DIAGRAM NOTES:

- THE FOLLOWING WIRING DIAGRAMS AND NOTES ARE INTENDED TO SERVE AS A BASIS OF DESIGN FOR THE IECC CONTROLLED RECEPTACLES. CONTRACTOR MAY PROPOSE AND SUBMIT ALTERNATE SOLUTIONS WHICH WILL BE SUBJECT TO REVIEW AND APPROVAL BY A/E.
- IF SUBMITTING WIRELESS LIGHTING AND/OR RECEPTACLE CONTROLS, PROVIDE SUBMITTAL WITH EQUIVALENT FUNCTION AS BASIS OF DESIGN OR CONTACT THE ENGINEER OF RECORD FOR WIRELESS WIRING DIAGRAMS.
- WHERE CONTROLS ARE BEING PROVIDED TO CONTROL RECEPTACLES AND NOT LIGHTING SYSTEMS, UTILIZE A RELAY PANEL FOR CONTROL OF RECEPTACLE DEVICES RATHER THAN UTILIZING SENSOR DEVICES.

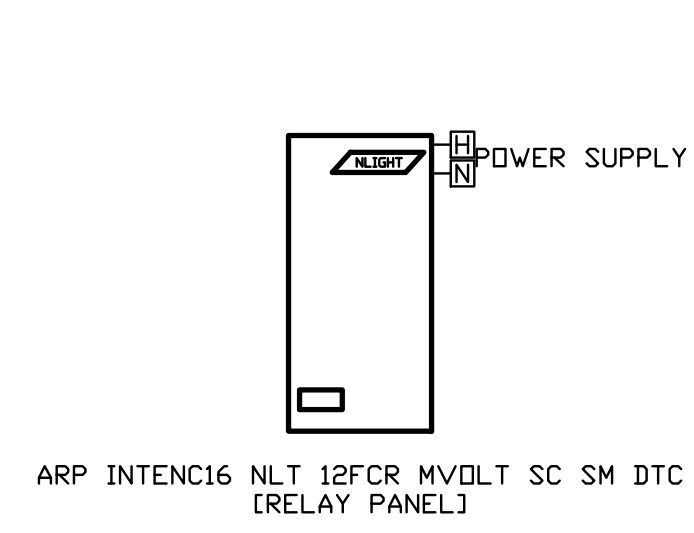

1 Relay Panel for Receptacle control

- NOTES:
- REFER TO PLANS FOR QTY. OF RELAYS REQUIRED.
 - RELAY PANEL TO INCLUDE INTEGRAL TIME-CLOCK FOR SCHEDULED CONTROL OF RECEPTACLES TO MEET ENERGY CODE.
 - ACUITY SHOWN AS BASIS OF DESIGN, CRESTRON EQUAL ACCEPTED.

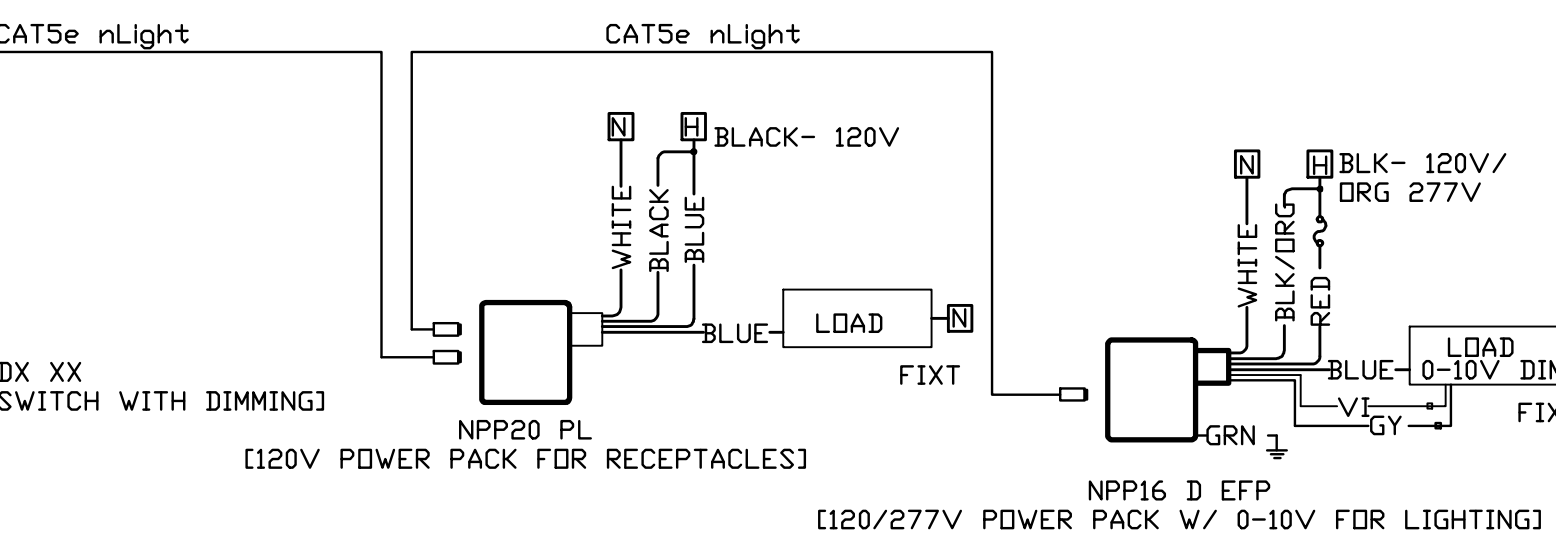
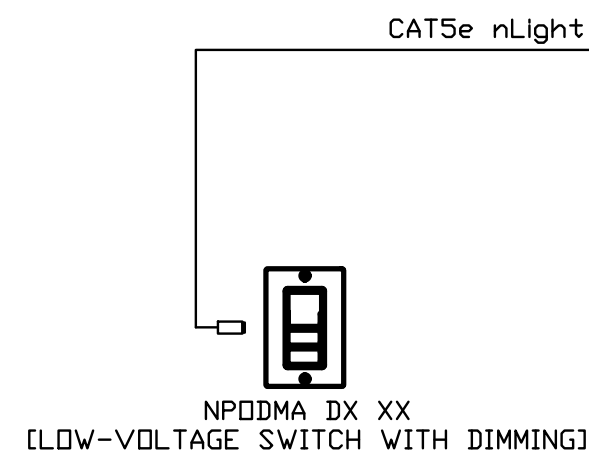

2 Wall Sensor with Receptacle control

- NOTES:
- DETAIL SHOWN FOR REFERENCE ONLY. REFER TO PLANS FOR QTY. OF POWER PACK, SENSORS AND KEYPADS.
 - ACUITY SHOWN AS BASIS OF DESIGN, CRESTRON EQUAL ACCEPTED.
 - LIGHTS TO BE AUTO ON TO 50% / AUTO OFF
 - RECEPTACLES TO BE AUTO ON / AUTO OFF

3 Ceiling Sensor with Receptacle control not to scale

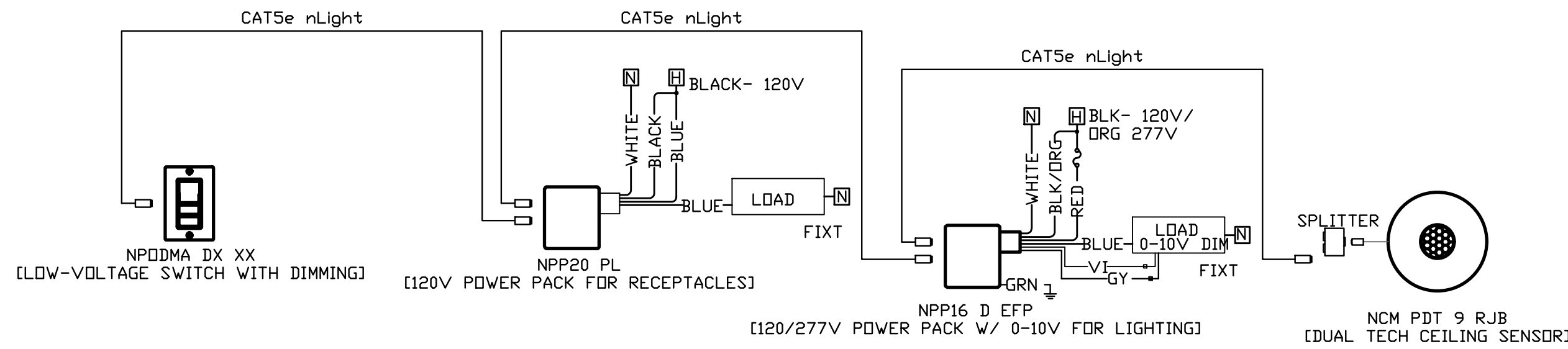

- NOTES:
- DETAIL SHOWN FOR REFERENCE ONLY. REFER TO PLANS FOR QTY. OF POWER PACK, SENSORS AND KEYPADS.
 - ACUITY SHOWN AS BASIS OF DESIGN, CRESTRON EQUAL ACCEPTED.
 - LIGHTS TO BE AUTO ON TO 50% / AUTO OFF
 - RECEPTACLES TO BE AUTO ON / AUTO OFF

NAME OF SPACE	CONTROL ZONE							
	TYPE 1	TYPE 2	TYPE 3	TYPE 4	TYPE 5	TYPE 6	TYPE 7	TYPE 8
SHELL SPACES, EXTERIOR/FACADES/STAIRWAYS, STAIRWAY SPANNING/STAIR PASSAGEWAYS, EXTERIOR PARKING AREAS	X							X
CORRIDORS	X	X						X
RESTROOMS/LOCKER ROOMS		X						X
INTERIOR GARAGES	X	X						X
JAMBOREESTORAGE ROOMS/LOUNGES			X					X
EVAM ROOMS/TREATMENT ROOMS (ELEC. (EOP. MECH. ELEVATOR, ETC.)				X				
COPY/PRINT ROOMS, BREAKROOMS, ENCLOSED OFFICES, CONFERENCE/MEETING/MULTIPURPOSE, CLASSROOMS/LECTURE/TRAINING ROOMS			X	X			X	X
OPEN PLAN OFFICE AREAS (LESS THAN 300 SF)	X	X					X	X
OPEN PLAN OFFICE AREAS (300 SF OR LARGER)	X	X			X	X	X	X
WAREHOUSE STORAGE AREAS					X			X
KITCHEN/PANTRY/FOOD PREP AREAS, GUEST ROOMS/SUITES/MULTIFAMILY UNITS, SENIOR LIVING UNITS, WORKSHOP AREAS		X		X				X
RETAIL AREAS, DINING ROOMS, BARS	X							

IF ADDITIONAL SPACES ARE REQUIRED THAT ARE NOT INDICATED ABOVE, PLEASE CONTACT EOR FOR CLARIFICATION ON LIGHTING CONTROL REQUIREMENTS

TYPE 1 TIMELOCK/PHOTOCELL CONTROL: ALL LIGHTING TO BE CONTROLLED BY TIMELOCK/PHOTOCELL CONTROL. EACH DIFFERENT FIXTURE TYPE IN A GIVEN AREA TO BE ON ITS OWN DIMMABLE RELAY. REFER TO ARCHITECT LIGHTING SCHEDULE FOR FURTHER INFORMATION OR REQUIREMENTS IF APPLICABLE. PROVIDE OVERRIDE SWITCH FOR AFTER-HOURS USE. COORDINATE SCHEDULING AND LOCATION OF SWITCH WITH ARCHITECT/OWNER. PROVIDE 150A RELAY FOR ALL ZONES SERVED BY GENERATOR OR CENTRAL INVERTER CIRCUITS. MINIMUM (1) RELAY PER ZONE. EXTERIOR TIMELOCK/PHOTOCELL CONTROL SHALL COMPLY WITH IECC C405.7 INCLUDING, BUT NOT LIMITED TO: DAYLIGHT SHUTOFF WHEN DAYLIGHT IS PRESENT; BUILDING FACADE AND LANDSCAPE LIGHTING TURN OFF NOT LATER THAN 1 HOUR AFTER BUSINESS CLOSING AND NOT EARLIER THAN 1 HOUR BEFORE BUSINESS OPENING; ALL OTHER EXTERIOR LIGHTING SHALL BE REDUCED BY NOT LESS THAN 50% FROM NOT LATER THAN MIDNIGHT TO NOT EARLIER THAN 4 AM. CAPABLE OF BEING PROGRAMMED FOR NOT FEVER THAN 7 DAYS; CAPABLE OF BEING PROGRAMMED FOR NOT FEVER THAN 7 DAYS; CAPABLE OF BEING SET FOR 7 DIFFERENT DAY TYPES PER WEEK; SHALL INCORPORATE AN AUTOMATIC HOLIDAY SETBACK FEATURE. INTERIOR TIMELOCK/PHOTOCELL CONTROL SHALL COMPLY WITH IECC C405.2 INCLUDING, BUT NOT LIMITED TO: TURN OFF LIGHTS WHEN SPACE IS SCHEDULED AS UNOCCUPIED; CAPABLE OF BEING PROGRAMMED FOR NOT FEVER THAN 7 DAYS; CAPABLE OF BEING PROGRAMMED FOR NOT FEVER THAN 7 DAYS; CAPABLE OF BEING SET FOR 7 DIFFERENT DAY TYPES PER WEEK; SHALL INCORPORATE AN AUTOMATIC HOLIDAY SETBACK FEATURE; AN INDIVIDUAL SWITCH SHALL NOT CONTROL MORE THAN AN AREA LARGER THAN 5,000 SQUARE FEET.

TYPE 2 OCCUPANCY SENSOR CONTROL: "AUTO ON, AUTO OFF" - SENSORS SHALL ACTIVATE FIXTURES TO TURN "ON" OR "OFF" BASED OFF OF OCCUPANCY. COORDINATE MANUAL DIMMING SWITCH REQUIREMENTS WITH ARCHITECT/OWNER. WHEN NO OCCUPANCY HAS BEEN DETECTED FOR UP TO A MAXIMUM OF 20 MINUTES, THE SENSOR WILL TURN ALL FIXTURES "OFF". CORRIDORS SHALL BE AUTO OFF UP TO 50% BRIGHTNESS. CONNECT TO TIMELOCK AS WELL AS SENSOR CONTROL WHERE INDICATED ON MATRIX. OCCUPANCY SENSORS SHALL COMPLY WITH C405.3.1 INCLUDING, BUT NOT LIMITED TO: THEY SHALL AUTOMATICALLY TURN OFF LIGHTS WITHIN 20 MINUTES AFTER ALL OCCUPANTS HAVE LEFT THE SPACE; THEY SHALL NOT INCORPORATE A MANUAL CONTROL (C405.2.1.1) EXCEPT FOR:

TYPE 3 VACANCY SENSOR CONTROL: "AUTO ON, AUTO OFF" - THE LOW-VOLTAGE DIMMING SENSOR SWITCH WITHIN EACH ROOM SHALL ACTIVATE THE FIXTURES TO TURN "ON" OR "OFF". WHEN NO OCCUPANCY HAS BEEN DETECTED FOR UP TO A MAXIMUM OF 20 MINUTES, THE SENSOR WILL TURN ALL FIXTURES "OFF". SENSORS WILL NOT BE ABLE TO TURN "ON" TO HIGHER THAN 50% BRIGHTNESS. SMALLER ROOMS ARE PROVIDED WITH INTEGRAL SENSOR WITHIN DIMMING SWITCH. LARGER ROOMS ARE PROVIDED WITH CEILING MOUNTED VACANCY SENSORS AND DIMMING SWITCHES. CONNECT TO TIMELOCK AS WELL AS SENSOR CONTROL WHERE INDICATED ON MATRIX. VACANCY SENSORS SHALL COMPLY WITH C405.2.1.1 INCLUDING, BUT NOT LIMITED TO: THEY SHALL AUTOMATICALLY TURN OFF LIGHTS WITHIN 20 MINUTES AFTER ALL OCCUPANTS HAVE LEFT THE SPACE; THEY SHALL BE MANUAL ON OR CONTROLLED TO AUTOMATICALLY TURN ON LIGHTING TO NOT MORE THAN 50 PERCENT POWER; THEY SHALL INCORPORATE A MANUAL CONTROL TO ALLOW OCCUPANTS TO TURN OFF LIGHTS.

TYPE 4 MANUAL: ALL LIGHTING TO BE CONTROLLED BY LOCAL SWITCH ONLY. PROVIDE DIMMING SWITCHES FOR ALL OCCUPABLE AREAS AND CORRIDORS WITH UNITS OR GUEST ROOMS/SUITES. FOR GUEST ROOMS/SUITES, PROVIDE CAPTIVE CARKEY OR MASTER ROOM SWITCH.

TYPE 5 WAREHOUSE SENSOR CONTROL: "AUTO ON, AUTO OFF 50%" - SENSORS SHALL ACTIVATE FIXTURES TO TURN "ON" OR "OFF" BASED OFF OF OCCUPANCY. WHEN NO OCCUPANCY HAS BEEN DETECTED FOR UP TO A MAXIMUM OF 20 MINUTES, THE SENSOR WILL TURN ALL FIXTURES "OFF" UP TO 50%. PROVIDE INTEGRAL VACANCY SENSORS ON EACH LIGHT FIXTURE. LIGHTING IN EACH AISLEWAY SHALL BE CONTROLLED INDEPENDENT OF ALL OTHER AISLEWAYS AND OPEN AREAS.

TYPE 6 OPEN OFFICE SENSOR CONTROL: "AUTO ON, AUTO OFF" - SENSORS SHALL ACTIVATE FIXTURES TO TURN "ON" OR "OFF" BASED OFF OF OCCUPANCY. COORDINATE MANUAL DIMMING SWITCH REQUIREMENTS WITH ARCHITECT/OWNER. EACH INDIVIDUAL CONTROL ZONE IS LIMITED TO A MAXIMUM OF 800 SQUARE FEET. WHEN OCCUPANCY IS DETECTED WITHIN AN INDIVIDUAL ZONE, SENSORS SHALL ACTIVATE FIXTURES WITHIN ZONE TO TURN "ON". ALL LIGHTING WITHIN UNOCCUPIED OPEN OFFICE ZONES SHALL BE AUTO ON UP TO 20% BRIGHTNESS. WHEN NO OCCUPANCY HAS BEEN DETECTED IN ALL OPEN OFFICE ZONES FOR UP TO A MAXIMUM OF 20 MINUTES, THE SENSORS WILL TURN ALL LIGHT FIXTURES WITHIN THE OPEN OFFICE AREAS "OFF". CONNECT TO TIMELOCK AS WELL AS SENSOR CONTROL WHERE INDICATED ON MATRIX. IF TIMELOCK IS UTILIZED IN ADDITION TO OCCUPANCY SENSORS, OPEN OFFICE AREAS SHALL BE AUTO OFF UP TO 20% BRIGHTNESS WHEN NO OCCUPANCY IS DETECTED IN ALL OPEN OFFICE ZONES.

TYPE 7 RECEPTACLE CONTROL: "AUTO ON, AUTO OFF" - FOR NEW RECEPTACLES, PROVIDE SPLIT CONTROLLED RECEPTACLES CONTROLLED BY OCCUPANCY VACANCY SENSOR OR TIMELOCK. EACH ROOM INDICATED IN THE MATRIX. FOR NEW WORKSTATION POWER, PROVIDE HALF OF CIRCUITS FOR INDIVIDUAL WORKSTATIONS TO BE CONTROLLED BY OCCUPANCY VACANCY SENSOR OR TIMELOCK. SENSORS SHALL ACTIVATE CIRCUITS OR CONTROLLED BY SPLIT RECEPTACLES TO TURN "OFF" OR "ON". PROVIDE INTEGRAL VACANCY SENSORS ON EACH LIGHT FIXTURE. LIGHTING IN EACH AISLEWAY SHALL BE CONTROLLED INDEPENDENT OF ALL OTHER AISLEWAYS AND OPEN AREAS.

TYPE 8 DAYLIGHT SENSOR: PROVIDE DAYLIGHT SENSORS AS REQUIRED PER IECC C405.2.4. PRIMARY SCHEDULED DAYLIGHT CONTROL SHALL BE PROVIDED FOR PRIMARY ZONES WITH A TOTAL OF 150 WATTS OR MORE OF GENERAL LIGHTING. SECONDARY SCHEDULED DAYLIGHT CONTROL SHALL BE PROVIDED FOR TOPLIGHT ZONES WITH A TOTAL OF 300 WATTS OR MORE OF GENERAL LIGHTING. TOPLIGHT DAYLIGHT CONTROL SHALL BE PROVIDED FOR TOPLIGHT ZONES WITH A TOTAL OF 150 WATTS OR MORE OF GENERAL LIGHTING. PRIMARY SCHEDULED DAYLIGHT ZONE - WHEN NO LIGHT IS DETECTED FOR 15 MINUTES, LIGHTING SHALL BE REDUCED TO 50% OF FULL POWER. SECONDARY SCHEDULED DAYLIGHT ZONE - WHEN NO LIGHT IS DETECTED FOR 15 MINUTES, LIGHTING SHALL BE REDUCED TO 50% OF FULL POWER. LONGITUDINALLY FROM EDGE TO NEAREST FULL HEIGHT WALL OR UP TO 5 TIMES HEIGHT EITHER SIDE OF PENETRATION. SECONDARY SCHEDULED DAYLIGHT ZONE - WHEN NO LIGHT IS DETECTED FOR 15 MINUTES, LIGHTING SHALL BE REDUCED TO 50% OF FULL POWER. LONGITUDINALLY FROM EDGE TO NEAREST FULL HEIGHT WALL OR UP TO 5 TIMES HEIGHT EITHER SIDE OF PENETRATION. LONGITUDINALLY FROM EDGE TO NEAREST FULL HEIGHT WALL OR UP TO 5 TIMES HEIGHT EITHER SIDE OF PENETRATION. SECONDARY SCHEDULED DAYLIGHT ZONE - WHEN NO LIGHT IS DETECTED FOR 15 MINUTES, LIGHTING SHALL BE REDUCED TO 50% OF FULL POWER. LONGITUDINALLY FROM EDGE TO NEAREST FULL HEIGHT WALL OR UP TO 5 TIMES HEIGHT EITHER SIDE OF PENETRATION. LONGITUDINALLY FROM EDGE TO NEAREST FULL HEIGHT WALL OR UP TO 5 TIMES HEIGHT EITHER SIDE OF PENETRATION. SECONDARY SCHEDULED DAYLIGHT ZONE - WHEN NO LIGHT IS DETECTED FOR 15 MINUTES, LIGHTING SHALL BE REDUCED TO 50% OF FULL POWER. LONGITUDINALLY FROM EDGE TO NEAREST FULL HEIGHT WALL OR UP TO 5 TIMES HEIGHT EITHER SIDE OF PENETRATION. LONGITUDINALLY FROM EDGE TO NEAREST FULL HEIGHT WALL OR UP TO 5 TIMES HEIGHT EITHER SIDE OF PENETRATION. SECONDARY SCHEDULED DAYLIGHT ZONE - WHEN NO LIGHT IS DETECTED FOR 15 MINUTES, LIGHTING SHALL BE REDUCED TO 50% OF FULL POWER. LONGITUDINALLY FROM EDGE TO NEAREST FULL HEIGHT WALL OR UP TO 5 TIMES HEIGHT EITHER SIDE OF PENETRATION. LONGITUDINALLY FROM EDGE TO NEAREST FULL HEIGHT WALL OR UP TO 5 TIMES HEIGHT EITHER SIDE OF PENETRATION. SECONDARY SCHEDULED DAYLIGHT ZONE - WHEN NO LIGHT IS DETECTED FOR 15 MINUTES, LIGHTING SHALL BE REDUCED TO 50% OF FULL POWER. LONGITUDINALLY FROM EDGE TO NEAREST FULL HEIGHT WALL OR UP TO 5 TIMES HEIGHT EITHER SIDE OF PENETRATION. LONGITUDINALLY FROM EDGE TO NEAREST FULL HEIGHT WALL OR UP TO 5 TIMES HEIGHT EITHER SIDE OF PENETRATION. SECONDARY SCHEDULED DAYLIGHT ZONE - WHEN NO LIGHT IS DETECTED FOR 15 MINUTES, LIGHTING SHALL BE REDUCED TO 50% OF FULL POWER. LONGITUDINALLY FROM EDGE TO NEAREST FULL HEIGHT WALL OR UP TO 5 TIMES HEIGHT EITHER SIDE OF PENETRATION. LONGITUDINALLY FROM EDGE TO NEAREST FULL HEIGHT WALL OR UP TO 5 TIMES HEIGHT EITHER SIDE OF PENETRATION. SECONDARY SCHEDULED DAYLIGHT ZONE - WHEN NO LIGHT IS DETECTED FOR 15 MINUTES, LIGHTING SHALL BE REDUCED TO 50% OF FULL POWER. LONGITUDINALLY FROM EDGE TO NEAREST FULL HEIGHT WALL OR UP TO 5 TIMES HEIGHT EITHER SIDE OF PENETRATION. LONGITUDINALLY FROM EDGE TO NEAREST FULL HEIGHT WALL OR UP TO 5 TIMES HEIGHT EITHER SIDE OF PENETRATION. SECONDARY SCHEDULED DAYLIGHT ZONE - WHEN NO LIGHT IS DETECTED FOR 15 MINUTES, LIGHTING SHALL BE REDUCED TO 50% OF FULL POWER. LONGITUDINALLY FROM EDGE TO NEAREST FULL HEIGHT WALL OR UP TO 5 TIMES HEIGHT EITHER SIDE OF PENETRATION. LONGITUDINALLY FROM EDGE TO NEAREST FULL HEIGHT WALL OR UP TO 5 TIMES HEIGHT EITHER SIDE OF PENETRATION. SECONDARY SCHEDULED DAYLIGHT ZONE - WHEN NO LIGHT IS DETECTED FOR 15 MINUTES, LIGHTING SHALL BE REDUCED TO 50% OF FULL POWER. LONGITUDINALLY FROM EDGE TO NEAREST FULL HEIGHT WALL OR UP TO 5 TIMES HEIGHT EITHER SIDE OF PENETRATION. LONGITUDINALLY FROM EDGE TO NEAREST FULL HEIGHT WALL OR UP TO 5 TIMES HEIGHT EITHER SIDE OF PENETRATION. SECONDARY SCHEDULED DAYLIGHT ZONE - WHEN NO LIGHT IS DETECTED FOR 15 MINUTES, LIGHTING SHALL BE REDUCED TO 50% OF FULL POWER. LONGITUDINALLY FROM EDGE TO NEAREST FULL HEIGHT WALL OR UP TO 5 TIMES HEIGHT EITHER SIDE OF PENETRATION. LONGITUDINALLY FROM EDGE TO NEAREST FULL HEIGHT WALL OR UP TO 5 TIMES HEIGHT EITHER SIDE OF PENETRATION. SECONDARY SCHEDULED DAYLIGHT ZONE - WHEN NO LIGHT IS DETECTED FOR 15 MINUTES, LIGHTING SHALL BE REDUCED TO 50% OF FULL POWER. LONGITUDINALLY FROM EDGE TO NEAREST FULL HEIGHT WALL OR UP TO 5 TIMES HEIGHT EITHER SIDE OF PENETRATION. LONGITUDINALLY FROM EDGE TO NEAREST FULL HEIGHT WALL OR UP TO 5 TIMES HEIGHT EITHER SIDE OF PENETRATION. SECONDARY SCHEDULED DAYLIGHT ZONE - WHEN NO LIGHT IS DETECTED FOR 15 MINUTES, LIGHTING SHALL BE REDUCED TO 50% OF FULL POWER. LONGITUDINALLY FROM EDGE TO NEAREST FULL HEIGHT WALL OR UP TO 5 TIMES HEIGHT EITHER SIDE OF PENETRATION. LONGITUDINALLY FROM EDGE TO NEAREST FULL HEIGHT WALL OR UP TO 5 TIMES HEIGHT EITHER SIDE OF PENETRATION. SECONDARY SCHEDULED DAYLIGHT ZONE - WHEN NO LIGHT IS DETECTED FOR 15 MINUTES, LIGHTING SHALL BE REDUCED TO 50% OF FULL POWER. LONGITUDINALLY FROM EDGE TO NEAREST FULL HEIGHT WALL OR UP TO 5 TIMES HEIGHT EITHER SIDE OF PENETRATION. LONGITUDINALLY FROM EDGE TO NEAREST FULL HEIGHT WALL OR UP TO 5 TIMES HEIGHT EITHER SIDE OF PENETRATION. SECONDARY SCHEDULED DAYLIGHT ZONE - WHEN NO LIGHT IS DETECTED FOR 15 MINUTES, LIGHTING SHALL BE REDUCED TO 50% OF FULL POWER. LONGITUDINALLY FROM EDGE TO NEAREST FULL HEIGHT WALL OR UP TO 5 TIMES HEIGHT EITHER SIDE OF PENETRATION. LONGITUDINALLY FROM EDGE TO NEAREST FULL HEIGHT WALL OR UP TO 5 TIMES HEIGHT EITHER SIDE OF PENETRATION. SECONDARY SCHEDULED DAYLIGHT ZONE - WHEN NO LIGHT IS DETECTED FOR 15 MINUTES, LIGHTING SHALL BE REDUCED TO 50% OF FULL POWER. LONGITUDINALLY FROM EDGE TO NEAREST FULL HEIGHT WALL OR UP TO 5 TIMES HEIGHT EITHER SIDE OF PENETRATION. LONGITUDINALLY FROM EDGE TO NEAREST FULL HEIGHT WALL OR UP TO 5 TIMES HEIGHT EITHER SIDE OF PENETRATION. SECONDARY SCHEDULED DAYLIGHT ZONE - WHEN NO LIGHT IS DETECTED FOR 15 MINUTES, LIGHTING SHALL BE REDUCED TO 50% OF FULL POWER. LONGITUDINALLY FROM EDGE TO NEAREST FULL HEIGHT WALL OR UP TO 5 TIMES HEIGHT EITHER SIDE OF PENETRATION. LONGITUDINALLY FROM EDGE TO NEAREST FULL HEIGHT WALL OR UP TO 5 TIMES HEIGHT EITHER SIDE OF PENETRATION. SECONDARY SCHEDULED DAYLIGHT ZONE - WHEN NO LIGHT IS DETECTED FOR 15 MINUTES, LIGHTING SHALL BE REDUCED TO 50% OF FULL POWER. LONGITUDINALLY FROM EDGE TO NEAREST FULL HEIGHT WALL OR UP TO 5 TIMES HEIGHT EITHER SIDE OF PENETRATION. LONGITUDINALLY FROM EDGE TO NEAREST FULL HEIGHT WALL OR UP TO 5 TIMES HEIGHT EITHER SIDE OF PENETRATION. SECONDARY SCHEDULED DAYLIGHT ZONE - WHEN NO LIGHT IS DETECTED FOR 15 MINUTES, LIGHTING SHALL BE REDUCED TO 50% OF FULL POWER. LONGITUDINALLY FROM EDGE TO NEAREST FULL HEIGHT WALL OR UP TO 5 TIMES HEIGHT EITHER SIDE OF PENETRATION. LONGITUDINALLY FROM EDGE TO NEAREST FULL HEIGHT WALL OR UP TO 5 TIMES HEIGHT EITHER SIDE OF PENETRATION. SECONDARY SCHEDULED DAYLIGHT ZONE - WHEN NO LIGHT IS DETECTED FOR 15 MINUTES, LIGHTING SHALL BE REDUCED TO 50% OF FULL POWER. LONGITUDINALLY FROM EDGE TO NEAREST FULL HEIGHT WALL OR UP TO 5 TIMES HEIGHT EITHER SIDE OF PENETRATION. LONGITUDINALLY FROM EDGE TO NEAREST FULL HEIGHT WALL OR UP TO 5 TIMES HEIGHT EITHER SIDE OF PENETRATION. SECONDARY SCHEDULED DAYLIGHT ZONE - WHEN NO LIGHT IS DETECTED FOR 15 MINUTES, LIGHTING SHALL BE REDUCED TO 50% OF FULL POWER. LONGITUDINALLY FROM EDGE TO NEAREST FULL HEIGHT WALL OR UP TO 5 TIMES HEIGHT EITHER SIDE OF PENETRATION. LONGITUDINALLY FROM EDGE TO NEAREST FULL HEIGHT WALL OR UP TO 5 TIMES HEIGHT EITHER SIDE OF PENETRATION. SECONDARY SCHEDULED DAYLIGHT ZONE - WHEN NO LIGHT IS DETECTED FOR 15 MINUTES, LIGHTING SHALL BE REDUCED TO 50% OF FULL POWER. LONGITUDINALLY FROM EDGE TO NEAREST FULL HEIGHT WALL OR UP TO 5 TIMES HEIGHT EITHER SIDE OF PENETRATION. LONGITUDINALLY FROM EDGE TO NEAREST FULL HEIGHT WALL OR UP TO 5 TIMES HEIGHT EITHER SIDE OF PENETRATION. SECONDARY SCHEDULED DAYLIGHT ZONE - WHEN NO LIGHT IS DETECTED FOR 15 MINUTES, LIGHTING SHALL BE REDUCED TO 50% OF FULL POWER. LONGITUDINALLY FROM EDGE TO NEAREST FULL HEIGHT WALL OR UP TO 5 TIMES HEIGHT EITHER SIDE OF PENETRATION. LONGITUDINALLY FROM EDGE TO NEAREST FULL HEIGHT WALL OR UP TO 5 TIMES HEIGHT EITHER SIDE OF PENETRATION. SECONDARY SCHEDULED DAYLIGHT ZONE - WHEN NO LIGHT IS DETECTED FOR 15 MINUTES, LIGHTING SHALL BE REDUCED TO 50% OF FULL POWER. LONGITUDINALLY FROM EDGE TO NEAREST FULL HEIGHT WALL OR UP TO 5 TIMES HEIGHT EITHER SIDE OF PENETRATION. LONGITUDINALLY FROM EDGE TO NEAREST FULL HEIGHT WALL OR UP TO 5 TIMES HEIGHT EITHER SIDE OF PENETRATION. SECONDARY SCHEDULED DAYLIGHT ZONE - WHEN NO LIGHT IS DETECTED FOR 15 MINUTES, LIGHTING SHALL BE REDUCED TO 50% OF FULL POWER. LONGITUDINALLY FROM EDGE TO NEAREST FULL HEIGHT WALL OR UP TO 5 TIMES HEIGHT EITHER SIDE OF PENETRATION. LONGITUDINALLY FROM EDGE TO NEAREST FULL HEIGHT WALL OR UP TO 5 TIMES HEIGHT EITHER SIDE OF PENETRATION. SECONDARY SCHEDULED DAYLIGHT ZONE - WHEN NO LIGHT IS DETECTED FOR 15 MINUTES, LIGHTING SHALL BE REDUCED TO 50% OF FULL POWER. LONGITUDINALLY FROM EDGE TO NEAREST FULL HEIGHT WALL OR UP TO 5 TIMES HEIGHT EITHER SIDE OF PENETRATION. LONGITUDINALLY FROM EDGE TO NEAREST FULL HEIGHT WALL OR UP TO 5 TIMES HEIGHT EITHER SIDE OF PENETRATION. SECONDARY SCHEDULED DAYLIGHT ZONE - WHEN NO LIGHT IS DETECTED FOR 15 MINUTES, LIGHTING SHALL BE REDUCED TO 50% OF FULL POWER. LONGITUDINALLY FROM EDGE TO NEAREST FULL HEIGHT WALL OR UP TO 5 TIMES HEIGHT EITHER SIDE OF PENETRATION. LONGITUDINALLY FROM EDGE TO NEAREST FULL HEIGHT WALL OR UP TO 5 TIMES HEIGHT EITHER SIDE OF PENETRATION. SECONDARY SCHEDULED DAYLIGHT ZONE - WHEN NO LIGHT IS DETECTED FOR 15 MINUTES, LIGHTING SHALL BE REDUCED TO 50% OF FULL POWER. LONGITUDINALLY FROM EDGE TO NEAREST FULL HEIGHT WALL OR UP TO 5 TIMES HEIGHT EITHER SIDE OF PENETRATION. LONGITUDINALLY FROM EDGE TO NEAREST FULL HEIGHT WALL OR UP TO 5 TIMES HEIGHT EITHER SIDE OF PENETRATION. SECONDARY SCHEDULED DAYLIGHT ZONE - WHEN NO LIGHT IS DETECTED FOR 15 MINUTES, LIGHTING SHALL BE REDUCED TO 50% OF FULL POWER. LONGITUDINALLY FROM EDGE TO NEAREST FULL HEIGHT WALL OR UP TO 5 TIMES HEIGHT EITHER SIDE OF PENETRATION. LONGITUDINALLY FROM EDGE TO NEAREST FULL HEIGHT WALL OR UP TO 5 TIMES HEIGHT EITHER SIDE OF PENETRATION. SECONDARY SCHEDULED DAYLIGHT ZONE - WHEN NO LIGHT IS DETECTED FOR 15 MINUTES, LIGHTING SHALL BE REDUCED TO 50% OF FULL POWER. LONGITUDINALLY FROM EDGE TO NEAREST FULL HEIGHT WALL OR UP TO 5 TIMES HEIGHT EITHER SIDE OF PENETRATION. LONGITUDINALLY FROM EDGE TO NEAREST FULL HEIGHT WALL OR UP TO 5 TIMES HEIGHT EITHER SIDE OF PENETRATION. SECONDARY SCHEDULED DAYLIGHT ZONE - WHEN NO LIGHT IS DETECTED FOR 15 MINUTES, LIGHTING SHALL BE REDUCED TO 50% OF FULL POWER. LONGITUDINALLY FROM EDGE TO NEAREST FULL HEIGHT WALL OR UP TO 5 TIMES HEIGHT EITHER SIDE OF PENETRATION. LONGITUDINALLY FROM EDGE TO NEAREST FULL HEIGHT WALL OR UP TO 5 TIMES HEIGHT EITHER SIDE OF PENETRATION. SECONDARY SCHEDULED DAYLIGHT ZONE - WHEN NO LIGHT IS DETECTED FOR 15 MINUTES, LIGHTING SHALL BE REDUCED TO 50% OF FULL POWER. LONGITUDINALLY FROM EDGE TO NEAREST FULL HEIGHT WALL OR UP TO 5 TIMES HEIGHT EITHER SIDE OF PENETRATION. LONGITUDINALLY FROM EDGE TO NEAREST FULL HEIGHT WALL OR UP TO 5 TIMES HEIGHT EITHER SIDE OF PENETRATION. SECONDARY SCHEDULED DAYLIGHT ZONE - WHEN NO LIGHT IS DETECTED FOR 15 MINUTES, LIGHTING SHALL BE REDUCED TO 50% OF FULL POWER. LONGITUDINALLY FROM EDGE TO NEAREST FULL HEIGHT WALL OR UP TO 5 TIMES HEIGHT EITHER SIDE OF PENETRATION. LONGITUDINALLY FROM EDGE TO NEAREST FULL HEIGHT WALL OR UP TO 5 TIMES HEIGHT EITHER SIDE OF PENETRATION. SECONDARY SCHEDULED DAYLIGHT ZONE - WHEN NO LIGHT IS DETECTED FOR 15 MINUTES, LIGHTING SHALL BE REDUCED TO 50% OF FULL POWER. LONGITUDINALLY FROM EDGE TO NEAREST FULL HEIGHT WALL OR UP TO 5 TIMES HEIGHT EITHER SIDE OF PENETRATION. LONGITUDINALLY FROM EDGE TO NEAREST FULL HEIGHT WALL OR UP TO 5 TIMES HEIGHT EITHER SIDE OF PENETRATION. SECONDARY SCHEDULED DAYLIGHT ZONE - WHEN NO LIGHT IS DETECTED FOR 15 MINUTES, LIGHTING SHALL BE REDUCED TO 50% OF FULL POWER. LONGITUDINALLY FROM EDGE TO NEAREST FULL HEIGHT WALL OR UP TO 5 TIMES HEIGHT EITHER SIDE OF PENETRATION. LONGITUDINALLY FROM EDGE TO NEAREST FULL HEIGHT WALL OR UP TO 5 TIMES HEIGHT EITHER SIDE OF PENETRATION. SECONDARY SCHEDULED DAYLIGHT ZONE - WHEN NO LIGHT IS DETECTED FOR 15 MINUTES, LIGHTING SHALL BE REDUCED TO 50% OF FULL POWER. LONGITUDINALLY FROM EDGE TO NEAREST FULL HEIGHT WALL OR UP TO 5 TIMES HEIGHT EITHER SIDE OF PENETRATION. LONGITUDINALLY FROM EDGE TO NEAREST FULL HEIGHT WALL OR UP TO 5 TIMES HEIGHT EITHER SIDE OF PENETRATION. SECONDARY SCHEDULED DAYLIGHT ZONE - WHEN NO LIGHT IS DETECTED FOR 15 MINUTES, LIGHTING SHALL BE REDUCED TO 50% OF FULL POWER. LONGITUDINALLY FROM EDGE TO NEAREST FULL HEIGHT WALL OR UP TO 5 TIMES HEIGHT EITHER SIDE OF PENETRATION. LONGITUDINALLY FROM EDGE TO NEAREST FULL HEIGHT WALL OR UP TO 5 TIMES HEIGHT EITHER SIDE OF PENETRATION. SECONDARY SCHEDULED DAYLIGHT ZONE - WHEN NO LIGHT IS DETECTED FOR 15 MINUTES, LIGHTING SHALL BE REDUCED TO 50% OF FULL POWER. LONGITUDINALLY FROM EDGE TO NEAREST FULL HEIGHT WALL OR UP TO 5 TIMES HEIGHT EITHER SIDE OF PENETRATION. LONGITUDINALLY FROM EDGE TO NEAREST FULL HEIGHT WALL OR UP TO 5 TIMES HEIGHT EITHER SIDE OF PENETRATION. SECONDARY SCHEDULED DAYLIGHT ZONE - WHEN NO LIGHT IS DETECTED FOR 15 MINUTES, LIGHTING SHALL BE REDUCED TO 50% OF FULL POWER. LONGITUDINALLY FROM EDGE TO NEAREST FULL HEIGHT WALL OR UP TO 5 TIMES HEIGHT EITHER SIDE OF PENETRATION. LONGITUDINALLY FROM EDGE TO NEAREST FULL HEIGHT WALL OR UP TO 5 TIMES HEIGHT EITHER SIDE OF PENETRATION. SECONDARY SCHEDULED DAYLIGHT ZONE - WHEN NO LIGHT IS DETECTED FOR 15 MINUTES, LIGHTING SHALL BE REDUCED TO 50% OF FULL POWER. LONGITUDINALLY FROM EDGE TO NEAREST FULL HEIGHT WALL OR UP TO 5 TIMES HEIGHT EITHER SIDE OF PENETRATION. LONGITUDINALLY FROM EDGE TO NEAREST FULL HEIGHT WALL OR UP TO 5 TIMES HEIGHT EITHER SIDE OF PENETRATION. SECONDARY SCHEDULED DAYLIGHT ZONE - WHEN NO LIGHT IS DETECTED FOR 15 MINUTES, LIGHTING SHALL BE REDUCED TO 50% OF FULL POWER. LONGITUDINALLY FROM EDGE TO NEAREST FULL HEIGHT WALL OR UP TO 5 TIMES HEIGHT EITHER SIDE OF PENETRATION. LONGITUDINALLY FROM EDGE TO NEAREST FULL HEIGHT WALL OR UP TO 5 TIMES HEIGHT EITHER SIDE OF PENETRATION. SECONDARY SCHEDULED DAYLIGHT ZONE - WHEN NO LIGHT IS DETECTED FOR 15 MINUTES, LIGHTING SHALL BE REDUCED TO 50% OF FULL POWER. LONGITUDINALLY FROM EDGE TO NEAREST FULL HEIGHT WALL OR UP TO 5 TIMES HEIGHT EITHER SIDE OF PENETRATION. LONGITUDINALLY FROM EDGE TO NEAREST FULL HEIGHT WALL OR UP TO 5 TIMES HEIGHT EITHER SIDE OF PENETRATION. SECONDARY SCHEDULED DAYLIGHT ZONE - WHEN NO LIGHT IS DETECTED FOR 15 MINUTES, LIGHTING SHALL BE REDUCED TO 50% OF FULL POWER. LONGITUDINALLY FROM EDGE TO NEAREST FULL HEIGHT WALL OR UP TO 5 TIMES HEIGHT EITHER SIDE OF PENETRATION. LONGITUDINALLY FROM EDGE TO NEAREST FULL HEIGHT WALL OR UP TO 5 TIMES HEIGHT EITHER SIDE OF PENETRATION. SECONDARY SCHEDULED DAYLIGHT ZONE - WHEN NO LIGHT IS DETECTED FOR 15 MINUTES, LIGHTING SHALL BE REDUCED TO 50% OF FULL POWER. LONGITUDINALLY FROM EDGE TO NEAREST FULL HEIGHT WALL OR UP TO 5 TIMES HEIGHT EITHER SIDE OF PENETRATION. LONGITUDINALLY FROM EDGE TO NEAREST FULL HEIGHT WALL OR UP TO 5 TIMES HEIGHT EITHER SIDE OF PENETRATION. SECONDARY SCHEDULED DAYLIGHT ZONE - WHEN NO LIGHT IS DETECTED FOR 15 MINUTES, LIGHTING SHALL BE REDUCED TO 50% OF FULL POWER. LONGITUDINALLY FROM EDGE TO NEAREST FULL HEIGHT WALL OR UP TO 5 TIMES HEIGHT EITHER SIDE OF PENETRATION. LONGITUDINALLY FROM EDGE TO NEAREST FULL HEIGHT WALL OR UP TO 5 TIMES HEIGHT EITHER SIDE OF PENETRATION. SECONDARY SCHEDULED DAYLIGHT ZONE - WHEN NO LIGHT IS DETECTED FOR 15 MINUTES, LIGHTING SHALL BE REDUCED TO 50% OF FULL POWER. LONGITUDINALLY FROM EDGE TO NEAREST FULL HEIGHT WALL OR UP TO 5 TIMES HEIGHT EITHER SIDE OF PENETRATION. LONGITUDINALLY FROM EDGE TO NEAREST FULL HEIGHT WALL OR UP TO 5 TIMES HEIGHT EITHER SIDE OF PENETRATION. SECONDARY SCHEDULED DAYLIGHT ZONE - WHEN NO LIGHT IS DETECTED FOR 15 MINUTES, LIGHTING SHALL BE REDUCED TO 50% OF FULL POWER. LONGITUDINALLY FROM EDGE TO NEAREST FULL HEIGHT WALL OR UP TO 5 TIMES HEIGHT EITHER SIDE OF PENETRATION. LONGITUDINALLY FROM EDGE TO NEAREST FULL HEIGHT WALL OR UP TO 5 TIMES HEIGHT EITHER SIDE OF PENETRATION. SECONDARY SCHEDULED DAYLIGHT ZONE - WHEN NO LIGHT IS DETECTED FOR 15 MINUTES, LIGHTING SHALL BE REDUCED TO 50% OF FULL POWER. LONGITUDINALLY FROM EDGE TO NEAREST FULL HEIGHT WALL OR UP TO 5 TIMES HEIGHT EITHER SIDE OF PENETRATION. LONGITUDINALLY FROM EDGE TO NEAREST FULL HEIGHT WALL OR UP TO 5 TIMES HEIGHT EITHER SIDE OF PENETRATION. SECONDARY SCHEDULED DAYLIGHT ZONE - WHEN NO LIGHT IS DETECTED FOR 15 MINUTES, LIGHTING SHALL BE REDUCED TO 50% OF FULL POWER. LONGITUDINALLY FROM EDGE TO NEAREST FULL HEIGHT WALL OR UP TO 5 TIMES HEIGHT EITHER SIDE OF PENETRATION. LONGITUDINALLY FROM EDGE TO NEAREST FULL HEIGHT WALL OR UP TO 5 TIMES HEIGHT EITHER SIDE OF PENETRATION. SECONDARY SCHEDULED DAYLIGHT ZONE - WHEN NO LIGHT IS DETECTED FOR 15 MINUTES, LIGHTING SHALL BE REDUCED TO 50% OF FULL POWER. LONGITUDINALLY FROM EDGE TO NEAREST FULL HEIGHT WALL OR UP TO 5 TIMES HEIGHT EITHER SIDE OF PENETRATION. LONGITUDINALLY FROM EDGE TO NEAREST FULL HEIGHT WALL OR UP TO 5 TIMES HEIGHT EITHER SIDE OF PENETRATION. SECONDARY SCHEDULED DAYLIGHT ZONE - WHEN NO LIGHT IS DETECTED FOR 15 MINUTES, LIGHTING SHALL BE REDUCED TO 50% OF FULL POWER. LONGITUDINALLY FROM EDGE TO NEAREST FULL HEIGHT WALL OR UP TO 5 TIMES HEIGHT EITHER SIDE OF PENETRATION. LONGITUDINALLY FROM EDGE TO NEAREST FULL HEIGHT WALL OR UP TO 5 TIMES HEIGHT EITHER SIDE OF PENETRATION. SECONDARY SCHEDULED DAYLIGHT ZONE - WHEN NO LIGHT IS DETECTED FOR 15 MINUTES, LIGHTING SHALL BE REDUCED TO 50% OF FULL POWER. LONGITUDINALLY FROM EDGE TO NEAREST FULL HEIGHT WALL OR UP TO 5 TIMES HEIGHT EITHER SIDE OF PENETRATION. LONGITUDINALLY FROM EDGE TO NEAREST FULL HEIGHT WALL OR UP TO 5 TIMES HEIGHT EITHER SIDE OF PENETRATION. SECONDARY SCHEDULED DAYLIGHT ZONE - WHEN NO LIGHT IS DETECTED FOR 15 MINUTES, LIGHTING SHALL BE REDUCED TO 50% OF FULL POWER. LONGITUDINALLY FROM EDGE TO NEAREST FULL HEIGHT WALL OR UP TO 5 TIMES HEIGHT EITHER SIDE OF PENETRATION. LONGITUDINALLY FROM EDGE TO NEAREST FULL HEIGHT WALL OR UP TO 5 TIMES HEIGHT EITHER SIDE OF PENETRATION. SECONDARY SCHEDULED DAYLIGHT ZONE - WHEN NO LIGHT IS DETECTED FOR 15 MINUTES, LIGHTING SHALL BE REDUCED TO 50% OF FULL POWER. LONGITUDINALLY FROM EDGE TO NEAREST FULL HEIGHT WALL OR UP TO 5 TIMES HEIGHT EITHER SIDE OF PENETRATION. LONGITUDINALLY FROM EDGE TO NEAREST FULL HEIGHT WALL OR UP TO 5 TIMES HEIGHT EITHER